



# THE HILLS OF CARMEL

BOX HILL

## LEGEND

	Lot Boundary
	Contours Level - 0.5m Intervals
	Batter Line
	Stormwater Drainage
	Easement for Drain water - 1.5m wide
	Easement for Maintenance access and construction - 0.9m wide
	Easement for Electrical services
	Proposed Sewer connection
	Water connection
	Electrical connection
	LV Pillar
	Streetlight column
	Electrical padmount substation
	Telecommunication connection
	Gas connection
	Retaining wall
	Proposed path network
	Proposed Street Tree

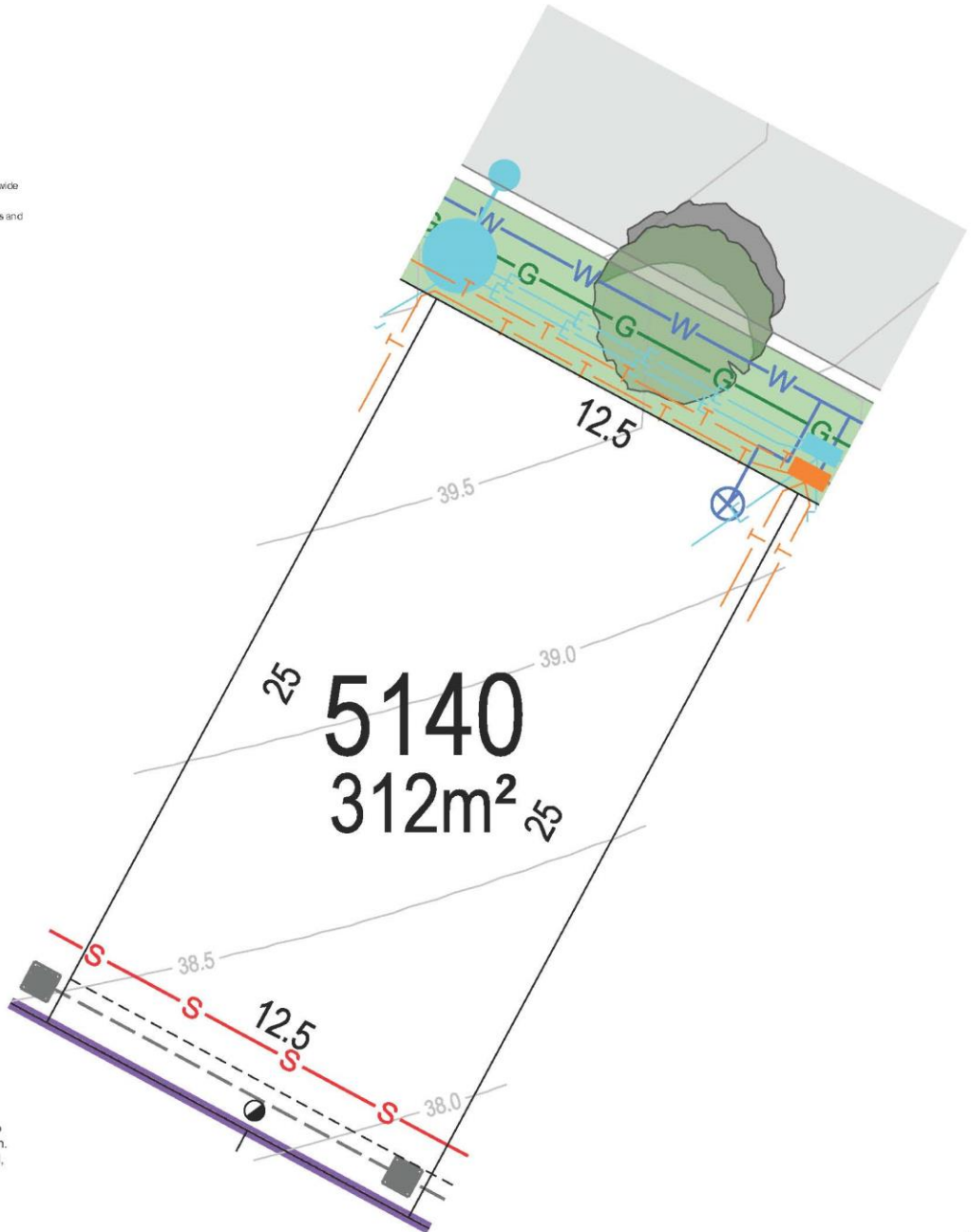

## NOTE

1. Dimensions and areas are subject to the registration of the deposited plan.
2. For restriction on the use of the land, positive covenants and location of easements and other requirements, refer to the deposited plan, 88B instrument and contract.
3. Prospective purchasers are to make their own enquiries with respect to the availability and location of services.
4. All care has been taken in the preparation of this brochure but no responsibility is taken for any errors or omissions.
5. Easement positions may vary subject to final work as executed survey.

Disclaimer: This material has been produced by The Hills of Carmel and associated entities and their appointed Agent and consultants for marketing and promotional purposes only. The Hills of Carmel would like to advise all prospective purchasers or investors to obtain independent advice from a suitably qualified person such as a solicitor, accountant or financial adviser and to make and rely on their own enquiries and investigations in relation to all statements, predictions and opinions contained in this material before purchasing land at this development. This material is intended as a general guide only and should not be relied upon in making a decision to purchase land at this development. The Hills of Carmel and associated entities disclaim all liability and responsibility for any loss, damage or claim of whatever nature suffered, sustained or incurred by any person, corporation or other legal entity, which arises out of any allgiance reliance on the contents of this material.